

ENSOL™ GULLY/ VACUUM /CESSPIT- EMPTIER/ VACUUM SUCKER



for Industrial & Municipal applications
Capacity Ranging: 3500Ltrs- 15,000Ltrs



Thoughtful design and superior build quality put the ENSOL range of Vacuum Tankers in a class of its own. All our tankers from 3500Liters to 15000 Liters are manufactured keeping specific end user applications in mind for Municipal & Industrial Applications.

DESIGN: All tankers are manufactured using 6mm high quality steel. Internal implosion rings are fitted to all tanks, which are then mounted on a strong chassis frame for maximum support. To ensure effective corrosion protection two coats of paint are applied to all tankers, an anti-corrosive primer and enamel finish, thus giving a high quality long lasting finish. Alternatively Vacuum Tankers can be galvanized up to and including 15,000 Liters models.

Advantage:

- Cleans blockages form most inaccessible points in sewers and storm water entrances.
- Low Maintenance, Easy to Operate

Available in 3000,3500,4500,8000 for Municipal Applications & upto 15,000 Liters for Industrial applications



ENSOL™ GULLY/ VACUUM /CESSPIT- EMPTIER/ VACUUM SUCKER

Also available on Trailer
Mounted Attachments

Also available on

- HIRE
- LEASING
- RENTAL

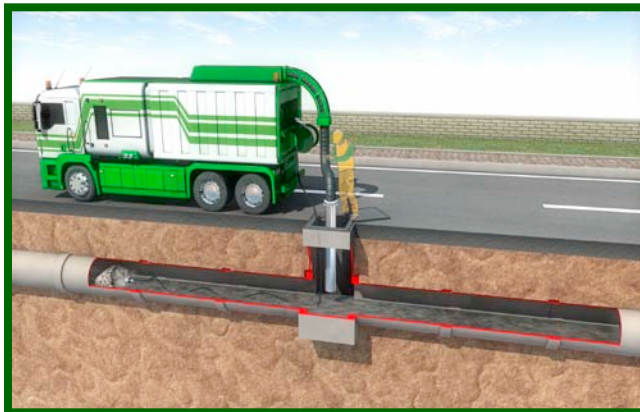

General Technical Specification:

Pump: Jurop-Italy, Imported rotary vane pump; SUCTION PIPE: 75 mm, 3 nos length of 2 Mtr each is provided with quick release coupler.

ADDITIONAL SUCTION FACILITY: 75 mm suction line with manually operated lever operated sluice valve with 15 meter long suction hose fitted with ball type metal suction strainer.

DERRICK ARM: (Derrick arm have 2700 swiveling with manually) up & down movement fitted on heavy duty rotary joint. The derrick arm movement in horizontal plane is to ensure easy reach of M.S. pipe attached to it to every corner of the septic tank.

TIPPING ARRANGEMENT: The discharge of sludge/waste from the tank is done by rear door which is manually opened. Tipping arrangement is provided to tilt the whole tank for the discharge of sludge by the rear door using hydraulic cylinder.

DRAIN VALVE: Manual option is also for discharge of sludge through 100 mm heavy duty slim seal butterfly/lever operated valve drain valve fitted in the bottom of tank.

ACCESSORIES & SAFETY DEVICES:	
QUICK COUPLER	Quick coupler made up of Aluminum of diameter sufficient to connect the existing hose pipe. It composed of male, female, ring & rubber gasket. Lever with hook is fitted on the female part for quick engaging & disengaging of hosepipe in very less time.
FLXIBLE LEVEL GAUGE	Flexible, Unbreakable Fitted through out the height of tank.
AUTO SHUTOFF VALVE	Valve mounted inside the tank, having dia of 6" which prevent over flowing of tank during suction operation.
PRESSURE RELIEF VALVE	Heavy duty spring type adjustable pressure relief valve is fitted.
UNIDIRECTIONAL VALVE	Fitted within the pump delivery line for preventing back pressure.
COMPOUND GAUGE	100 mm dia, range 0 to 4kg./cm2

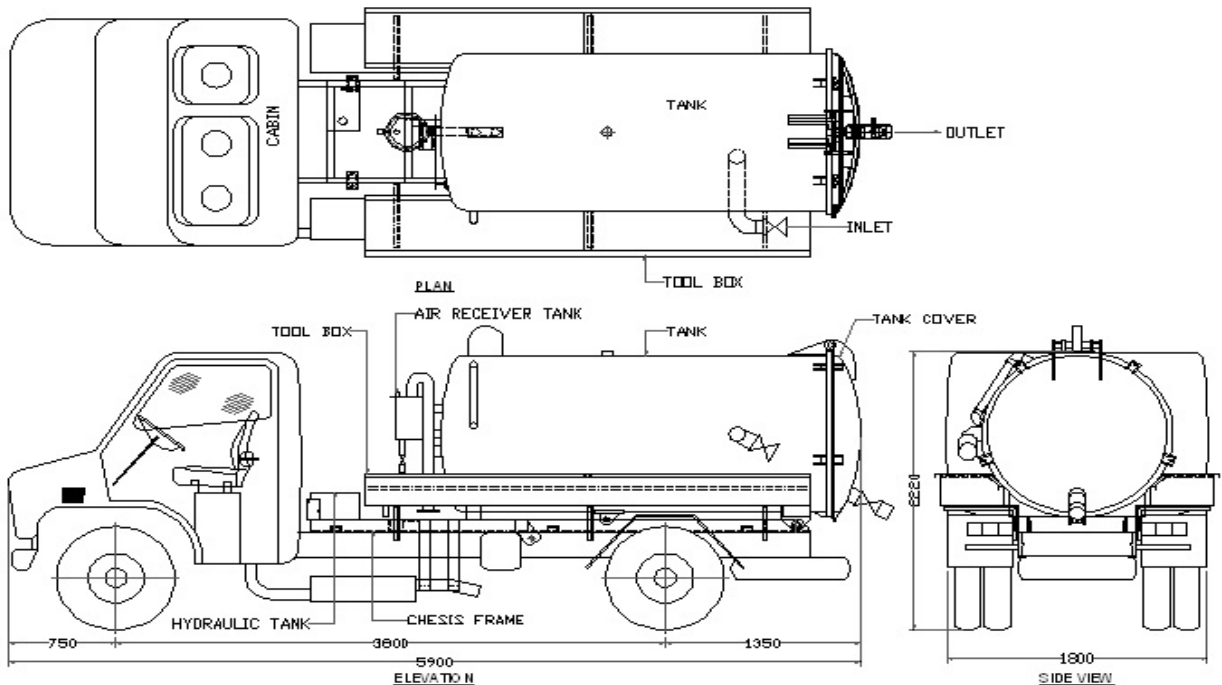

#For reference only. In the interest of technical development, we reserve the right to alter equipment without prior notice.

Ensol Multiclean Equipments Pvt. Ltd.

#401, Neelkanth, Opp. Sahakar Bhawan, Bhawani Singh Lane, Jaipur - 302 001 Raj. (India)
 Phone : +91-141-222 6933 | Facsimile : +91-141-222 6934 | E-mail : info@ensolindia.com
 Website : www.ensolindia.com | www.ensol.co.in